

Howell 2-Piece Full Port Brass Ball Valve

SPECIFICATIONS:

- Forged Brass Body
- Full Port Design
- 600 PSI WOG for 1/4" – 2"
- 400 PSI WOG for 2-1/2" – 4"
- 150 PSI Saturated Steam
- Blowout Proof Stem for Safety
- Threaded Ends
- Size Range: 1/4" – 4"



STANDARDS:

CSA Approved

- 1/2 PSI - CGA 9.1 / ANSI Z21.15
- 2 & 5 PSI - CGA CR91-002 / ASME B16.44
- 125 PSI – CGA 3.16 / ASME B16.33 & B16.38

UL Approved

- YQNZ – Compressed Gas
- YRBX – Flammable Liquid
- YRPV – Natural & Manufactured Gases
- YSDT – LP Gas

FM Approved

- FM-1140 – Quick Opening Valves (1/4 – 2")

NSF Approved

- NSF 61 Section 8 Certified

HOW TO ORDER:

Series - **Body** - **Ends** - **Size**
HQ104 - BR - IP

Sample Description and Part# :

HQ104-BR-IP-112

HQ104 UL/CGA 2PC BRASS IP BALL VALVE 1-1/2"

Pressure & Temperature Chart

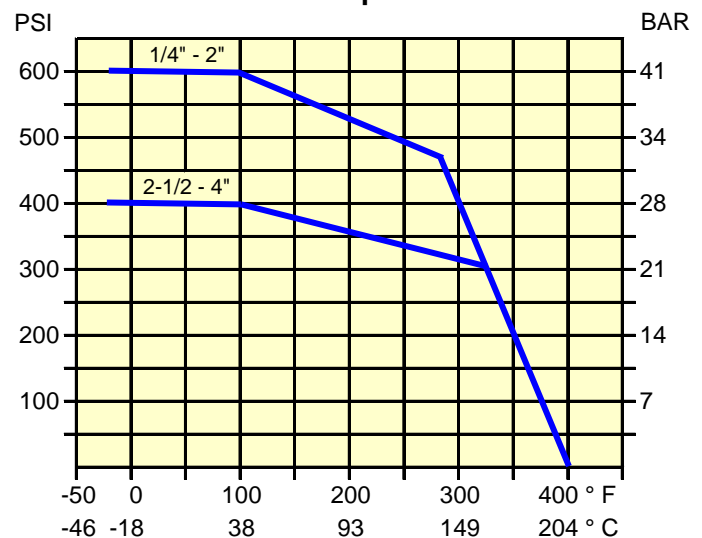



SERIES HQ104 2pc IP Brass

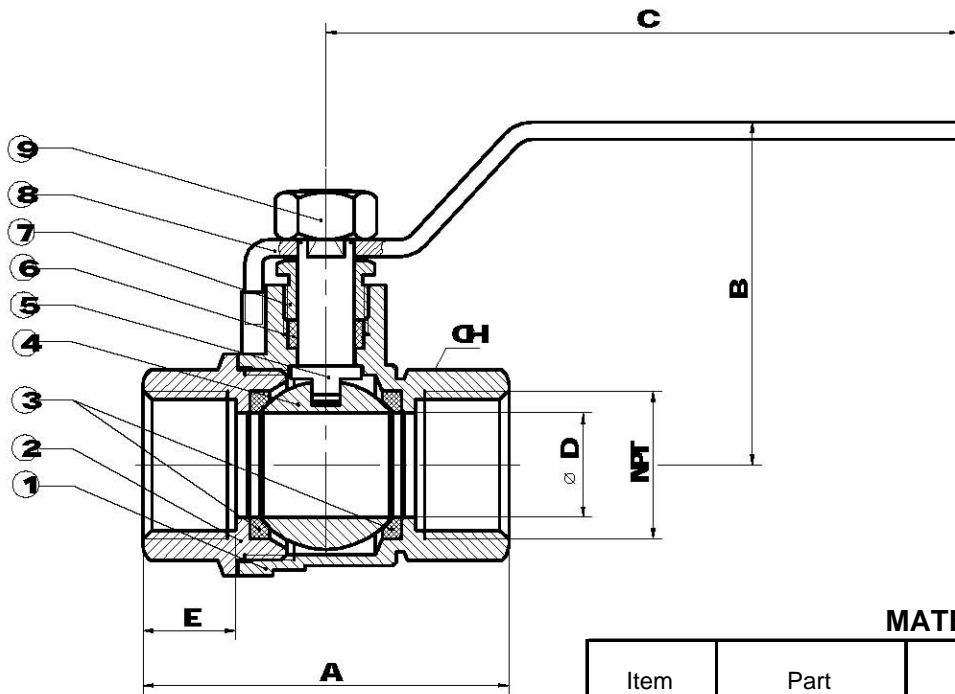

MATERIALS LIST:

Item	Part	For Brass Valve	Quantity
1	Body	Forged Brass ASTM C37700	1
2	End Cap	Forged Brass ASTM C37700	1
3	Seat	PTFE	2
4	Ball	Brass ASTM C37700	1
5	Stem	Brass ASTM C37700	1
6	Stem Packing	PTFE	1
7	Gland Nut	Brass ASTM C37700	1
8	Handle	Chrome Plated Steel / Vinyl Grip	1
9	Stem Nut	Nickel Plated Steel	1



DIMENSIONS:

SIZE	A		B		C		D		E		OH		Valve Weights	
	IN	MM	IN	MM	IN	MM	IN	MM	IN	MM	IN	MM	(KG)	(LB)
1/4"	1.68	42.6	1.67	42.5	2.76	70.0	0.32	8.0	0.46	11.6	0.71	18	0.2	0.4
3/8"	1.76	44.6	1.73	44.0	3.54	90.0	0.39	10.0	0.46	11.6	0.79	148	0.1	0.3
1/2"	2.05	52.0	1.92	48.8	3.54	90.0	0.55	14.0	0.52	13.2	0.98	25	0.2	0.5
3/4"	2.36	60.0	2.09	53.0	3.78	96.0	0.75	19.0	0.56	14.3	1.20	148	0.3	0.7
1"	2.76	70.0	2.59	65.8	4.53	115.0	0.95	24.0	0.63	16.0	1.49	178	0.5	1.1
1-1/4"	3.31	84.0	2.95	75.0	4.53	115.0	1.28	32.5	0.71	18.0	1.81	178	0.7	1.6
1-1/2"	3.68	93.5	3.35	85.0	5.51	140.0	1.58	40.0	0.72	18.2	2.09	53	1.1	2.5
2"	4.18	106.2	3.68	93.5	5.51	140.0	1.99	50.5	0.75	19.0	2.59	66	1.6	3.5
2-1/2"	5.36	136.2	4.76	121.0	8.66	220.0	2.52	64.0	1.09	27.8	3.39	178	3.4	7.4
3"	6.09	154.7	5.08	129.0	8.66	220.0	2.95	75.0	1.10	28.0	3.89	99	4.4	9.6
4"	7.39	187.6	5.89	149.5	9.61	244.0	3.89	98.8	1.22	31.0	4.88	124	8.1	17.8

Howell reserves the right to alter design specifications without notice.