

Howell 1-Piece Reduced Port Ball Valve

H1 Series

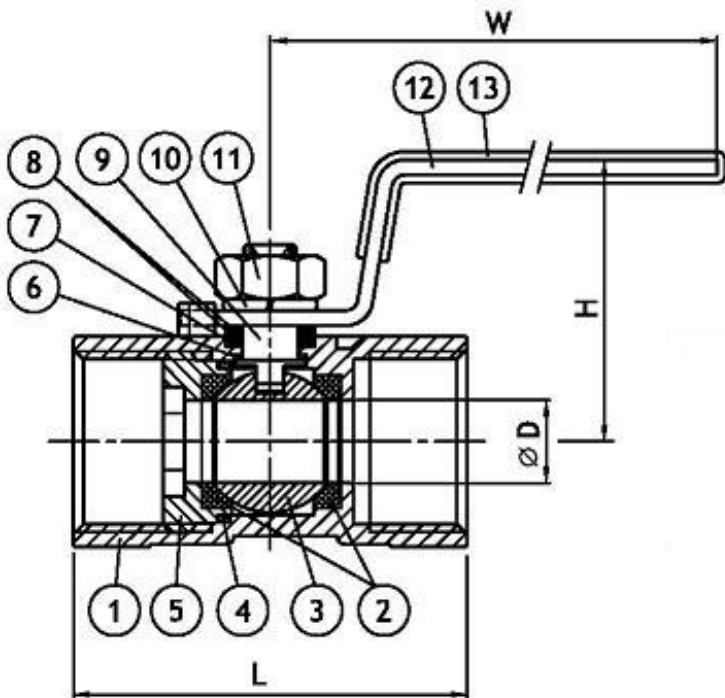

MATERIALS LIST:

Item	Part	For Stainless Steel Valve	Qty
1	Body	ASTM A351 CF8M	1
2	Seat	RPTFE	2
3	Ball	ASTM A351 CF8M	1
4	Joint Gasket	RPTFE	1
5	Body Insert	ASTM A351 CF8M	1
6	Thrust Washer	R-PTFE	1
7	Stem Packing	R-PTFE	1
8	Washer	304 SS	2
9	Stem	316 SS	1
10	Spring Washer	304 SS	1
11	Stem Nut	304 SS	1
12	Handle	304 SS	1
13	Handle Sleeve	Vinyl	1
14	Locking Device	304 SS	1

DIMENSIONS:

SIZE	D		E		H		L		W	
	IN	MM	IN	MM	IN	MM	IN	MM	IN	MM
1/4"	0.20	5	0.67	17	1.3	33.0	1.54	39	2.76	70
3/8"	0.28	7	0.83	21	1.42	36	1.73	44	3.15	80
1/2"	0.35	9	0.98	25	1.57	40	2.28	58	3.74	95
3/4"	0.49	12.5	1.26	32	1.77	45	2.32	59	3.74	95
1"	0.59	15	1.5	38	1.81	46	2.8	71	4.41	112
1-1/4"	0.79	20	1.89	48	1.97	50	3.07	78	4.41	112
1-1/2"	0.98	25	2.07	52.5	2.17	55	3.27	83	5.31	135
2"	1.26	32	2.56	65	2.56	65	3.94	100	5.31	135

Estimated Cv Values	
Size	Cv Value
1/4"	2
3/8"	4
1/2"	5
3/4"	8
1"	15
1-1/4"	33
1-1/2"	40
2"	70

Valve Weights		
Size	(KG)	(LB)
1/4"	0.1	0.2
3/8"	0.1	0.3
1/2"	0.2	0.4
3/4"	0.3	0.6
1"	0.4	1.0
1-1/4"	0.7	1.5
1-1/2"	0.8	1.8
2"	1.3	3.0

Howell reserves the right to alter design specifications without notice